

Studio Flash

E /Dp /HDp Series

FOMEX®



Contents

Part names and functions of control panel	-----	2
Operating procedure	-----	4
Model button control guide		
Replacement and maintenance	-----	5
Technical Specifications	-----	6
Notice	-----	7
Halogen lamps, safety measures	-----	8
Troubleshooting		
Warranty	-----	9

Please read the operating instructions before using the product.

While operating, if any abnormal condition or malfunction is observed, stop using the product immediately and contact the authorized dealer of its purchase location.



Part Names & Functions of Control panel

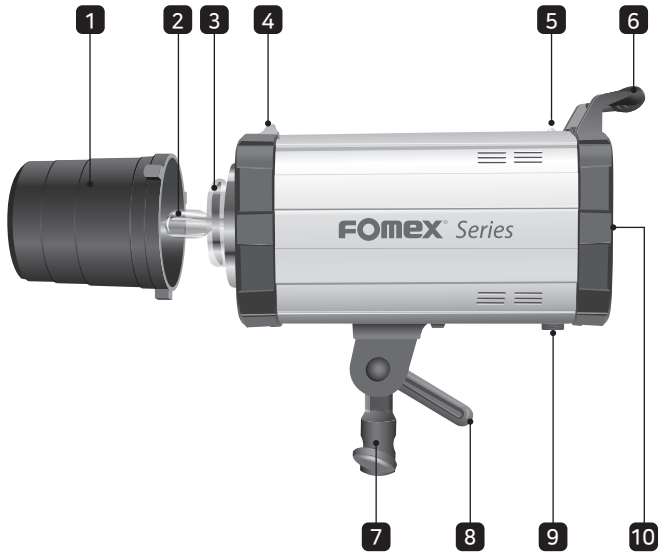

- | | |
|--|--------------------------|
| 1. Protection cap | 6. Lighting grip |
| 2. Modeling(Halogen) lamp | 7. Stand stud joint part |
| 3. Flash tube(Xenon Tube) | 8. Handle for fastening |
| 4. Locking knob for accessory assembly | 9. Wireless control port |
| 5. Slave sensor | 10. Control panel |



1. Slave sensor : Synchronize with other lighting.
2. BEEP button : Makes a beeping sound when the flash is charging or discharging.
3. CELL button : Controls the synchronization with other lightings.
4. MODEL button :
E series : ON/OFF
Dp/HdP series : RED, GREED, OFF
5. O.C Signal : Overcharge signal lamp turns on when over charged.
6. FND-Digitally display power output.
O.T Display : Over temperature warning, display "EO" on the FND
7. AC input : Socket terminal to connect the power cord.
8. SYNC : Socket terminal for synchro cord.
9. Fuse box : Contains fuse
10. Umbrella holder
11. TEST button : To test or to manually discharge the flash.
12. Modeling lamp control dial : Controls the brightness of the modeling lamp.
13. Flash power control dial : Controls the power of the flash.
14. Power switch (ON/OFF)
15. Wireless control port : Only available for Fomex's receiver (Option)



Operating procedure

1. The settings MODEL / BEEP / CELL buttons are OFF and the modeling & flash power dials are at a minimum.
2. Install the modeling lamp to the flash unit.
Be careful not to allow any fingerprint or dust stains on the lamp.
3. Connect the synchro cord to the synchro socket.
Turn ON the power switch.
4. Control the power of the flash with the flash power control dial.
5. Control the brightness of the modeling lamp with the modeling lamp control dial and press the MODEL button to turn it ON.
6. To synchronize with other lighting, press the CELL button to turn it ON.
7. When the power output setting is adjusted from high to low, the TEST button will flicker.
8. To turn ON/OFF the flash charging sound, press the BEEP button.
9. For wired synchronization plug the sync cord into the sync socket and connect it to the camera. (Use the hot shoes according to the camera model)
10. For wireless synchronization plug the receiver into the sync socket and connect the receiver to the camera to check the synchronization status.
(Select a channel based on your wireless synchronizer)

Dp/HDp Series Model button control guide

The MODEL button has 3 functions.

- RED LED ON : The brightness of the modeling lamp is adjusted by the modeling lamp control dial ranged from 0~100%.
- GREEN LED ON : Proportional setting is initiated. The brightness of the modeling lamp is adjusted by the flash power control dial variable from f2.2 ~f5.63.
- LED OFF : The modeling lamp is off.



Replacement and maintenance

A. How to replace a modeling lamp.

Screw type (Base : E-11)

1. Turn OFF the power and unplug the power cord from the AC socket.
2. Turn it counterclockwise and remove the modeling lamp.
3. Turn the new modeling lamp clockwise to install.
(Please make sure your hands are dry.)
4. Be careful not to allow any fingerprints, dust or stains on the lamp.
When a foreign substance is present clean with a soft cloth.

Pin type (Base : GX-6.35)

1. Allow the modeling lamp to cool down enough.
2. Turn it counterclockwise and remove it.
3. While assembling, turn it clockwise and then reassemble it.
4. Be careful not to allow any fingerprints, dust or stains on the lamp.
Clean it with a soft cloth applied with alcohol after replacement.

B. How to replace a fuse.

1. Turn OFF the power and unplug the power cord from the AC socket.
2. Use a (-) screwdriver and open the fuse box to pull out the fuse.
3. Check if the fuse is blown and replace it with the spare
fuse placed inside the fuse box.

C. Maintenance

Be sure not to let any dust or other stains on the flash tube and modeling lamp.

Wipe off any dust or foreign matter on the tube/lamp with a soft cloth.
It may shorten the lifespan and deteriorate the color temperature.

Technical Specifications



		E series	Dp series	HDp series
Flash Head	Power Control	6steps in 1/10 f-stops		
	Power Range Display	4.0 ~ 10 Digital		
	Color Temperature	5,500K (±150K)		
	Over Temperature Warning	Display (E0) on the FND / Warning Buzzer		
	Over Charge Warning	Red LED Light		
	Flash Ready Indicator	LED Light / Buzzer (Sound ON)		
POWER	AC Input Voltage	AC 220V 50/60Hz (AC 110V Option)		
	Fuse Capacity	10A		
Modeling Light	Type	Tungsten		
	Wattage	Halogen 250W (E 11base, Screw type)		Halogen 650W (GX 6.35 base)
	Control Modes	Volume controller, Model(ON/OFF)	Proportional, Volume controller, Model(ON/OFF)	
Sync	Sync Type	Cable, Optical, Radio(Optional)		
	Sync Voltage	DC 8V		
Cooling System		DC Cooling Fan		
Buttons		Model, Cell, Beep, Test ON/OFF		

	Maximum Power	F-Stop(1m, ISO100)	Recycle Time	Dimension mm (W x L x H)	Weight
200	200Ws	F22.6 (6f-stops)	0.1~0.7sec	296x140x220mm	2.3kg/5lbs
400	400Ws	F32.7 (6f-stops)	0.1~1.0sec	370x140x220mm	2.8kg/6.1lbs
600	600Ws	F45.5 (6f-stops)	0.1~1.3sec		3.0kg/6.6lbs
800	800Ws	F64.0 (6f-stops)	0.2~1.3sec	430x140x220mm	3.4kg/7.5lbs
1000	1000Ws	F64.2 (6f-stops)	0.3~1.7sec		3.6kg/8lbs

The listed values may differ due to tolerances in components and measuring instruments. Technical data is subjected to change without prior notice.



Notice

1. Check the input voltage.
2. When the input voltage is lower than the rated voltage, the flash may not produce its maximum output.
3. Disconnect this unit from the power supply before changing a bulb or a fuse.
Use the specified fuse only.
4. Do not use in humid or hazardous places or near inflammable materials.
5. The flash can stop working to enable cooling after maximum output and long-term continuous use.
6. Do not use the flash near the eyes.
7. For safety, please power OFF when not in use.
8. Do not move the flash while the power is on.
9. Make sure not to use a softbox near inflammable materials.
The heat emitted from the product may cause a fire.
10. Do not drop and shock the product.
11. When either assembling or disassembling accessories (e.g. snoot, reflector, etc.), turn OFF the modeling lamp and wait for at least 10 minutes before changing and replacing the accessories.
12. Never open this unit, high voltage inside. 
13. No internal serviceable parts.
14. The separation distance of the product is 0.5m at least. 
15. Fomex accepts no responsibility for electric shock or equipment damage due to unauthorized modification and repairs.
16. Keep out of children's reach.

 electric shock(symbol)

 0.5m over(symbol)

Halogen lamps safety measures

1. Avoid contact with bare hands and wear dry cloth or gloves when handling.
2. When moving the strobe turn off the power and treat it safely.
3. Make sure that the residual heat of the lamp is sufficiently cooled before handling.
4. When the lamp is overheated the lack of attention to the above precautions may lead to the risk of explosion. Be sure to use a protective device (Pyrex dome, Softbox) while in use.
5. Please keep a proper distance between the subject and the lamp when taking portraits, and do not use it without a protective device.

Troubleshooting

Status	Expected cause	Checkpoints
The slave is not working.	The CELL button is turned OFF.	Check whether the CELL button is turned ON.
	The flash light doesn't reach the slave sensor.	Change the directionality of the lighting unit. Check if it's still not working.
	A strong external light is directed at the slave sensor.	Block direct ray of light or strong light from the slave sensor.
The synchro cord doesn't work.	Foreign material presents on the synchro jack, it causes a contact defect.	Check the synchro jack for any presence of foreign materials, and clean it with a soft cloth.
	The synchro cord is disconnected or failed to function after cleaning.	Replace the synchro cord. (Press the TEST button to check)
There's no reaction at all.	The Power Supply is interrupted	Check if the power cord is properly connected. Check if the contact of the socket is loose. Check if the fuse is blown.
Other trouble shoots	Please contact your local dealer or contact FOMEX directly.	



Warranty

Fomex's warranty provisions of the product are listed as below.

When a defect occurs within the warranty period, it will be repaired with new or refurbished parts for free.

Or, it will be replaced with a new product or a functionally equivalent refurbished product.

This warranty applies only to products manufactured by Fomex that can be identified by the trademark, trade name, or logo affixed to the product.

Inapplicable Warranty

The following cases are excluded from the warranty terms specified above.

1. Expired warranty period
2. Breakage or damage caused by inappropriate usage, repair, maintenance and accident.
 - 1) Installation and removal with improper external equipment or improper usage.
 - 2) Damage to the product caused by external fault or any accident.
 - 3) Exposure to extreme environment such as abnormal temperature, solvents, acids, bases, floods, humidity.
 - 4) External damage like scratches, crushes or cracks.
 - 5) If the serial number is defected or cannot be identified.
3. Damage caused by installation, repair, improvement, addition, disassembly by unauthorized institution or person.
4. Modified, replaced, removed information identifying the original product
5. Absence of valid warranty card
6. Unusable or damage caused by the use of illegal nonstandard and unofficial software
7. Damage caused by accident, abuse, misuse, floods, fires, earthquakes or other external causes.
8. Supplies such as flash tubes, lamps, charger capacitors, etc.

Please keep the confirmation of purchase and this warranty card for future service.

Customer Information	Name	
	Contact Number	
	Address	
Seller Information	Name	
	Contact Number	
	Address	
	Purchasing date	
Product	Name	



www.fomex.com

7th Floor, Seongsui-ro, Seongdong-gu, Seoul Korea 04787

Tel: +82 2 545 0004 Fax: +82 2 3444 9399 E-mail: info@fomex.com



VER.202107(EN)